



## DATA SHEET

**Product:** Evo Dual

**Product Code:** 03-10003

Doc Iss: 01



Note: Computer, Monitors, Keyboard & Mouse Not included



# DATA SHEET

Product: Evo Dual

Product Code: 03-10003

## Dimensions: Millimetre (mm)

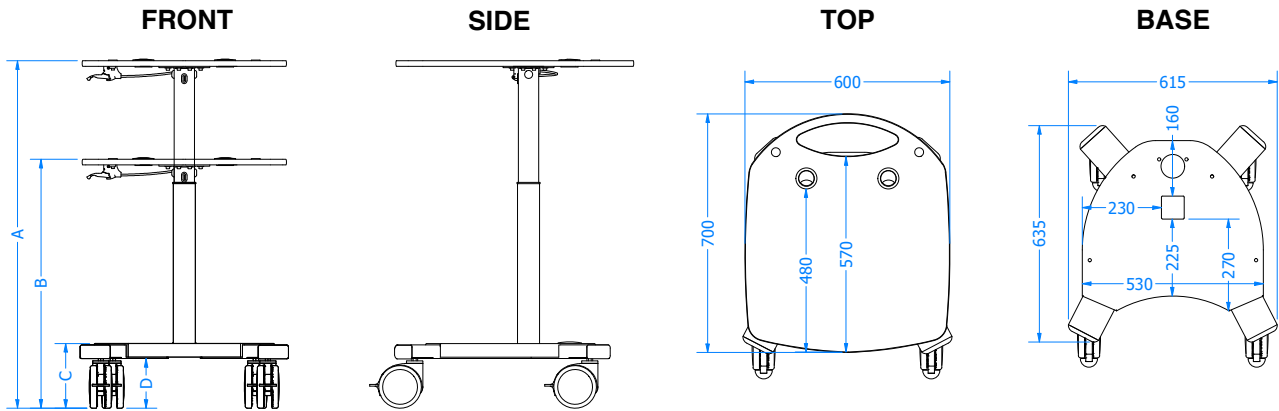

DIMENSION:	A	B	C	D
Single Castor:	1035	795	240	205
Dual Castor:	1020	780	240	190

### Core Key Features:

- Height Adjustable
- Lever positioned on the left or right
- Large Trespa top with rear handle 20kg max load (*other load options available*)
- Heavy duty steel base, ergonomic curved front recess
- Cable entry holes on both top and base
- Accessory mounting holes on both top and base
- 4 off braking swivel castors
- High ground clearance
- Material(s): Trespa, Aluminium, Steel, Plastic
- Finish(s): Anodised, Powder Coat Black Grey RAL7021 (*other colours are available*)
- Weight: 49kg

### Accessories Key Features

- Fully adjustable monitor arm,
  - Vesa 75 & 100 compliant
  - Post length options 100, 200, 300, 400, 500 and 700mm
  - Easy rotate between portrait and landscape
  - Suggested screen size (each): 24" (inch)
  - Max load: 12kg
- Keyboard Panel
  - Fully adjustable under worktop keyboard surface
  - Height adjustment of 170mm travel
  - Tilt the keyboard panel +/- 15°
  - Swivel left/right +/- 20°
  - Full length gel wrist rest
  - Max Load 1.5kg
- Mouse Panel
  - Position on the left or right
  - Swivel the panel under the top when not in use
  - Max load 1kg



## DATA SHEET

**Product:** Evo Dual

**Product Code:** 03-10003

---

- Shelf

Height adjustable

Depth adjustment of 10mm allowing for cable routing of electrical accessories

W520xD220mm

Max Load: 10kg

- Rear Cable Tray

Internal storage for small electronic devices, PDU, Cables, etc

Removable rear cover

Flexible cable chain connected to cart top

Front cable entry

### Cleaning

- Refer to the Evo Carts cleaning guide for detailed information

- Tested active agents

- ✓ Detergent & Disinfectants

- ✓ Alcohol Based

- ✓ Ammonia

- ✓ Chlorine

### Operation and Maintenance

- Secure any loose items before moving.

- Carefully lift castors over large thresholds.

- Position dual monitors with screens facing one another over the centre of the cart top before moving.

- Periodic general inspection, check fixings are secure, check free movement of any moving part.