



DATA SHEET

Product: Evo Comm

Product Code: 03-10004

Doc Iss: 01



Note: Computer, Monitor, Keyboard & Mouse Not included



DATA SHEET

Product: Evo Comm

Product Code: 03-10004

Dimensions: Millimetre (mm)

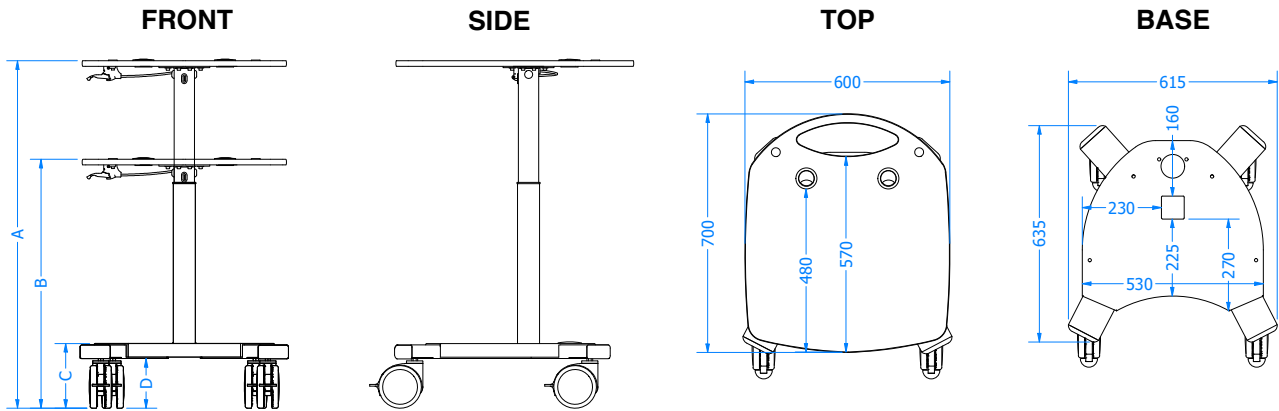

DIMENSION:	A	B	C	D
Single Castor:	1035	795	240	205
Dual Castor:	1020	780	240	190

Core Key Features:

- Height Adjustable
- Lever positioned on the left or right
- Large Trespa top with rear handle 20kg max load (*other load options available*)
- Heavy duty steel base, ergonomic curved front recess
- Cable entry holes on both top and base
- Accessory mounting holes on both top and base
- 4 off braking swivel castors
- High ground clearance
- Material(s): Trespa, Aluminium, Steel, Plastic
- Finish(s): Anodised, Powder Coat Black Grey RAL7021 (*other colours are available*)
- Weight: 48kg

Accessories Key Features

- Fully adjustable monitor arm,
 - Vesa 75 & 100 compliant
 - Post length options 100, 200, 300, 400, 500 and 700mm
 - Easy rotate between portrait and landscape
 - Suggested screen size: 27" (inch)
 - Max load: 12kg
- Cart Top Shelf 65mm
 - Open front to allow for quick access to your equipment
 - Positioned under the cart top, moving with the users height adjustment
 - Supplied with an internal 3mm thick black ribbed rubber protective mat
 - Internal dimensions W545xD250xH65mm
 - Max Load: 5kg



DATA SHEET

Product: Evo Comm

Product Code: 03-10004

- **Deep Draw**

- Lockable draw

- Positioned under the cart top, moving with the users height adjustment

- Smooth operation with ball bearing runners/slides

- Supplied with 2 keys

- Supplied with an internal 3mm thick black ribbed rubber protective mat

- Internal dimensions W530xD250xH200mm (height without rubber mat)

- Max load: 10kg

- **Rear Cable Tray**

- Internal storage for small electronic devices, PDU, Cables, etc

- Removable rear cover

- Flexible cable chain connected to cart top

- Front cable entry

Cleaning

- Refer to the Ergo-Cart cleaning guide for detailed information

- Tested active agents

- ✓ Detergent & Disinfectants

- ✓ Alcohol Based

- ✓ Ammonia

- ✓ Chlorine

Operation and Maintenance

- Secure any loose items before moving.

- Carefully lift castors over large thresholds.

- Periodic general inspection, check fixings are secure, check free movement of any moving part.